

TNP Digital Torque Meter

Torque Testing Instrument for Medical, Pharmaceutical and Industrial Quality Control, R&D and countless torque applications



The new TNP torque meter is a precision instrument that measures OPEN and CLOSE torque values for various applications. As a cap torque analyzer, the TNP repeatedly determines bottle closure and breakaway torque. It has a wide memory capacity capable of storing 1,000 data points in addition to Average, Maximum and Minimum values. A HI-LO comparator feature can be utilized for large batch testing to ensure overall product quality.

The TNP torque meter is USB capable for computer testing. Combined with the free Digitorq Software, additional analysis and testing can be performed.

The TNP is a portable device powered with internal rechargeable batteries or thru an AC adapter/charger. Designed with a small footprint it can easily be transferred to maximize use around the shop floor or the laboratory.

FEATURES & BENEFITS

High Accuracy	± 0.5% F.S.
Wide Torque Range	2Nm, 5Nm and 10Nm models
Adjustable Sample Size	Quick and easy set-up takes seconds
Test Memory	One touch operation, retains up to 1000 measurements
Variable Units of Measures:	Displays Torque values in, lb./in., Lbin, Kgcm and Nm, Ncm
Large Digital Display	Easy to read L.C.D.
PC Output	USB interface with add in software (Digitorq)
Flexible Power	Rechargeable NiMH batteries and / or Universal AC adapter
Selectable Measuring Modes	Captures Peak Opening, Closing and Average torque values (CCW, CW)
Portable	Small foot print, compact, space saver design

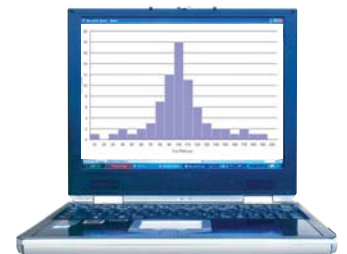

Free Digitorq Software with Graphing Capability



TNP Digital Torque Meter

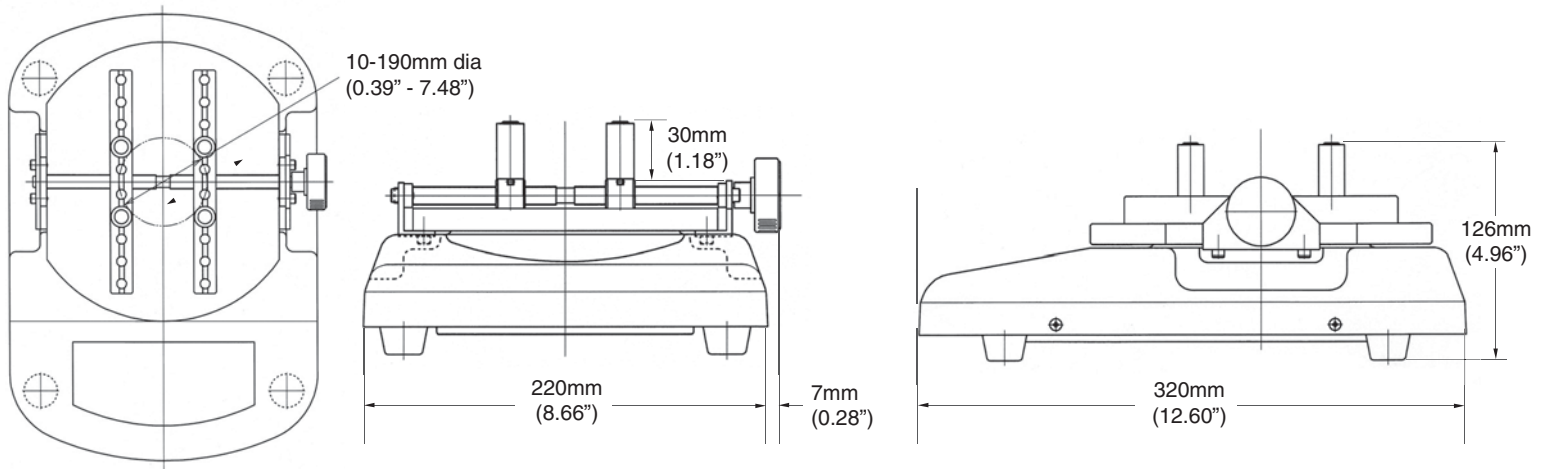

SPECIFICATIONS

TNP- XX Series Digital Torque Tester w/USB interface			
TNP Models	TNP-2	TNP-5	TNP-10
Measuring units	Nm, Ncm, Kgcm, lbin	Nm, Ncm, Kgcm, lbin	Nm, Ncm, Kgcm, lbin
Measuring range	0-2.000 Nm	0-5.00 Nm	0-10.00 Nm
	0-200.0 Ncm	0-500.0 Ncm	0-1000 Ncm
	0-20.39 Kgcm	0-50.99 Kgcm	0-102.0 Kgcm
	0-17.70 Lbin	0-44.25 Lbin	0-88.5 Lbin
Overload protection / Percentage overload	Yes / 150%		
Sample diameter range	Φ10 - 190 mm (0.39 " - 7.48")		
Overload display	Display "OVR" at sub display of LCD, blinking LED		
Display	Main display	4-digit LCD display Character height 12mm	
	Sub display	3-digit LCD display Character height 7mm	
	Comparator Display	HI, GO, LO LED	
Accuracy	± 0.5% F.S.		
Measuring mode	Opening mode	Show max value when opening (peak display) Displays max counter clockwise torque.	
	Closing mode	Show max value when closing (peak display) Displays max clockwise torque	
	Average mode	Real time display (average value display) Displays max torque in real time.	
Display Update Time	Select from 0.125 second (8times/second), 0.25 second (4 times/second), 0.5 second (2times/second), 1 second(1time/second). Peak display: 0.125 second		
Sampling Rate	1000 times/second		
Memory	Memory data number	1000 data (max)	
	Statistic process	Average value, max value min value	
Data output	USB1.1		
PC software	Digitorg software (free, download from web site: www.shimpoint.com)		
Accessories	USB cable, AC adapter, 30mm chuck pin (4pcs), Manual		
Power	Built in nickel hydride battery or Auto-ranging AC adapter (AC100 - 240V)		
Dimensions L x W x H mm/ in	320 x 227x 126 (12.60" x 8.94" x 4.96")		
Shipping weight	8 kg (17.62lb)	8 kg (17.62lb)	12.5 kg (27.53lb)
Operation environment	0 - 40 degree C / 32 - 104 degree F		
Certifications	CE approval		
Battery Life	8 hours after full charge		
Battery Recharge Time	Max. 16 hours		
Battery Type	NiMH		