



CL TECH AND SUPPLY CO., LTD.

27/92 Soi Arthornupatum , Pracharad 1 Rd., Bangsue , Bangkok 10800

Tel : 0-2587-3752

Fax : 0-2912-5223

Web Site : www.cltech.co.th E-Mail : sales@cltech.co.th

CTM-H42 (Capacity 20kN.)

Whole series equipped with high efficient servo motor and accurate ball screw transmission. Self-design controller and humanized software. Ensure every test has the same accuracy. Satisfy ASTM, ISO, JIS, EN, GB, BS, CNS and other International Standards. Satisfy the inspection and development demand for metal, nonmetal, fasteners, rubber/plastic, textile, paper, plastic tapes, electrical components, panels and relevant industries. 2 years warranty.



Regarding different test methods, we provide two different stroke machine.

Standard (800mm)/ Higher (1,100)





Capacity	20kN (2000kgf)
Stroke	800/1,100 mm (exclude grips)
Space	Ø425mm
Load Resolution	1/10,000 (Max 1/200,000)
Stroke Resolution	0.001mm
Motor	AC Servo motor
Speed	0.002~1000 mm/min
Width	930 mm
Depth	500 mm
Height	1,500/1,900 mm
Weight	150/170 kgf
Sampling Rate	500(Max.)
Power Supply	1Ø · 220V · 5A

Fastener / Metal Test

			
Tapping screw- Tensile	Withdrawal/pull-through	Bolt Tensile/Proof Load	Rod /Wire Tensile

Plastic & Rubber Test

Spring Test

				
Tensile(Rubber)	Tensile(Hard plastic)	3-point Bending	Tension	Compression

Aadhesive & Peeling Test

Clothing Test



180 deg.

90 deg.

Tensile
(Wave
Grip)

Puncture

Other Test **Accessories**

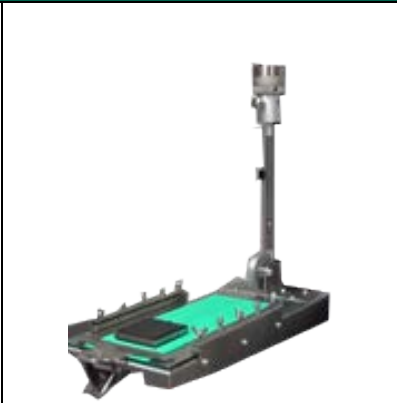
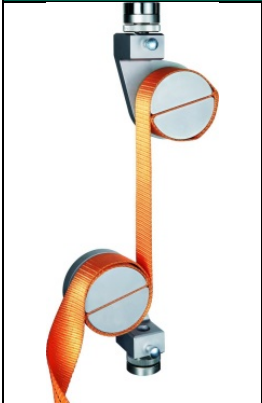

Tensile-
Webbing

String / Thread

Friction

Pneumatic
Grips

Biaxial table